

**Glenair Connector
Designator F**

MIL-DTL-38999 Series I & II,
40M38277, PAN 6433-1, PATT
614, PATT 616,
NFC93422 Series HE308 &
HE309

M85049/47 S W 10

Basic Part No. _____ Dash No. _____

Material and Finish Designator

S = Self-Locking _____ N = Aluminum, Electroless Nickel

Omit for Non-Self-Locking S = 300 Series Steel, Passivated

 W = Aluminum, 1,000 Hour Cadmium Olive
Drab Over Electroless Nickel

MS27507 B-10
SUPERCEDED SPEC.

Basic Part No. _____ Dash No. _____

(Non-Self-Locking)

Material and Finish Designator

B = Aluminum, 500 Hour Cadmium Olive

Drab Over Electroless Nickel

F = Aluminum, Electroless Nickel

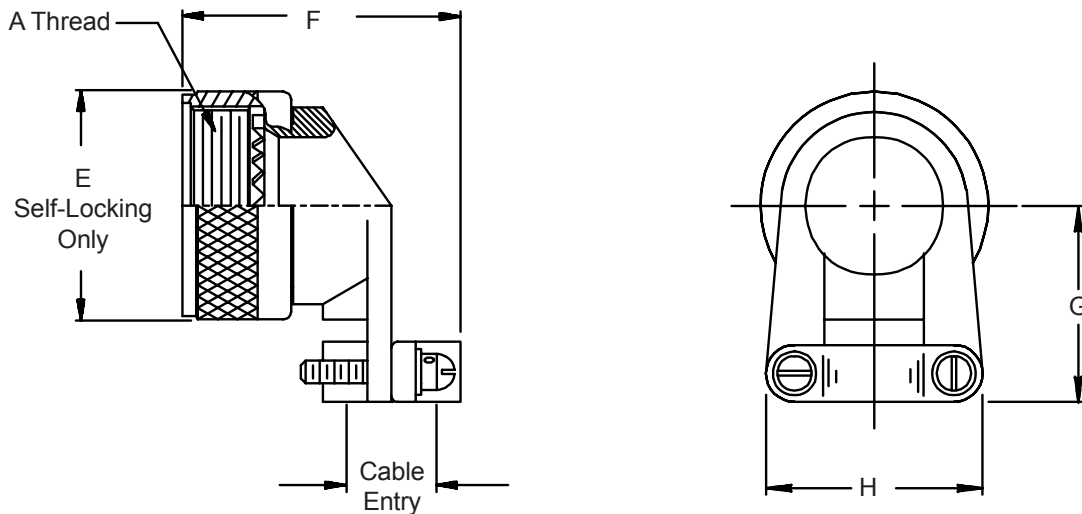
TABLE I

Dash No.	Shell Size Ref.	A Thread Class 2B	E Dia Max	F Max	G Max	H Max	Cable Entry	
							Min	Max
8	8/9	.438 - 28 UNEF	.86 (21.8)	1.38 (35.1)	1.00 (25.4)	.85 (21.6)	.098 (2.5)	.234 (5.9)
10	10/11	.562 - 24 UNEF	.98 (24.9)	1.38 (35.1)	1.10 (27.9)	.90 (22.9)	.153 (3.9)	.234 (5.9)
12	12/13	.688 - 24 UNEF	1.16 (29.5)	1.46 (37.1)	1.10 (27.9)	1.10 (27.9)	.190 (4.8)	.328 (8.3)
14	14/15	.813 - 20 UNEF	1.28 (32.5)	1.63 (41.4)	1.25 (31.8)	1.15 (29.2)	.260 (6.6)	.457 (11.6)
16	16/17	.938 - 20 UNEF	1.41 (35.8)	1.80 (45.7)	1.30 (33.0)	1.30 (33.0)	.283 (7.2)	.614 (15.6)
18	18/19	1.063 - 18 UNEF	1.52 (38.6)	1.82 (46.2)	1.35 (34.3)	1.50 (38.1)	.325 (8.3)	.634 (16.1)
20	20/21	1.188 - 18 UNEF	1.64 (41.7)	1.90 (48.3)	1.60 (40.6)	1.60 (40.6)	.343 (8.7)	.698 (17.7)
22	22/23	1.313 - 18 UNEF	1.77 (45.0)	2.04 (51.8)	1.75 (44.5)	1.70 (43.2)	.381 (9.7)	.823 (20.9)
24	24/25	1.438 - 18 UNEF	1.89 (48.0)	2.15 (54.6)	1.85 (47.0)	1.80 (45.7)	.418 (10.6)	.853 (21.7)

1. For complete dimensions see applicable Military Specification.
2. Metric dimensions (mm) are indicated in parentheses.
3. Cable Entry is defined as the accommodation entry for the wire bundle or cable. Dimensions are not intended for inspection criteria.