

# AS85049/58 Potting Boot Ring

Glenair Connector  
Designator F

MIL-C-38999 Series I & II,  
40M38277, PAN 6433-1,  
PATT 614, PATT 616,  
NFC93422 Series HE308 &  
HE309

**M85049/58-10**

Basic Part No. \_\_\_\_\_ Dash No. \_\_\_\_\_

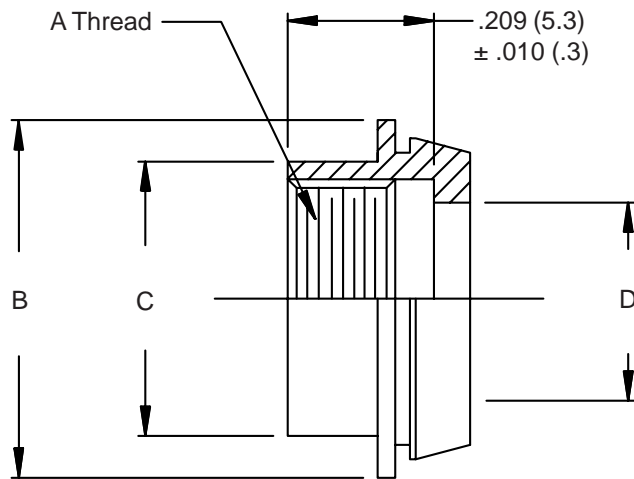

**TABLE I**

Dash No.	Shell Size Ref.	A Thread UNEF-2B	B Dia Max	C Dia Max	D Dia ±.005 (.1)
8	8/9	.4375 - 28	.600 (15.2)	.506 (12.9)	.344 (8.7)
10	10/11	.5625 - 24	.726 (18.4)	.631 (16.0)	.472 (12.0)
12	12/13	.6875 - 24	.850 (21.6)	.756 (19.2)	.586 (14.9)
14	14/15	.8125 - 20	.976 (24.8)	.881 (22.4)	.711 (18.1)
16	16/17	.9375 - 20	1.012 (25.7)	1.006 (25.6)	.836 (21.2)
18	18/19	1.0625 - 18	1.226 (31.1)	1.131 (28.7)	.942 (23.9)
20	20/21	1.1875 - 18	1.352 (34.3)	1.256 (31.9)	1.067 (27.1)
22	22/23	1.3125 - 18	1.476 (37.5)	1.381 (35.1)	1.192 (30.3)
24	24/25	1.4375 - 18	1.602 (40.7)	1.506 (38.3)	1.317 (33.5)

1. For complete dimensions see applicable Military Specification.
2. Metric dimensions (mm) are indicated in parentheses.
3. Finish: 500 Hour Cadmium Olive Drab Over Electroless Nickel.
4. See page 68-12 for M85049/75 potting boot which can be used with this potting ring.